

THIS DRAWING IS UNPUBLISHED. RELEASED FOR PUBLICATION, 19 .
 © COPYRIGHT 19 BY AMP INCORPORATED. ALL INTERNATIONAL RIGHTS RESERVED.

LOC	DIST	P	F	ZONE	LTR	REVISIONS	DATE	APPD
AJ	16				E	REDWN PER 0220-0412-94	6-3-94	JL

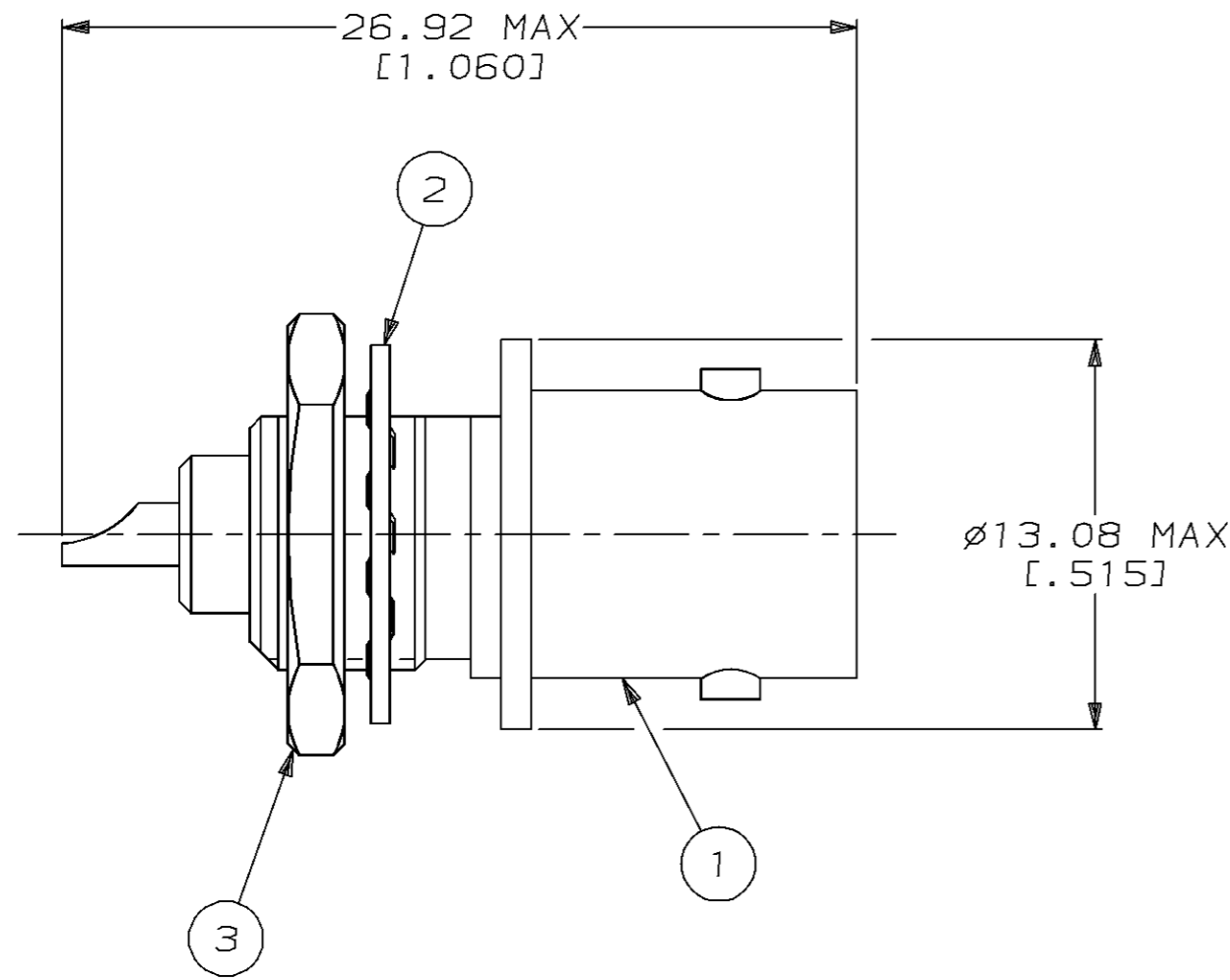

1. .125 MAX PANEL THICKNESS.

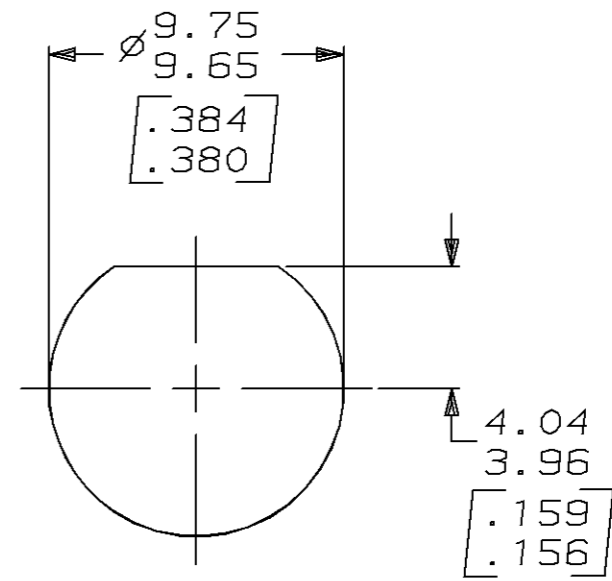

RECOMMENDED PANEL CUTOUT

	1-330249-1	1-329492-1	227717-3	227715-3
SUPERSEDED BY 227715-3	1-330249-1	1-329492-1	227717-2	227715-2
SUPERSEDED BY 227715-3	1-330249-1	1-329492-1	227717-1	227715-1
3 JAM NUT QTY=1	2 LOCKWASHER QTY=1	1 JACK ASSY QTY=1	PART NUMBER	

DO NOT SCALE PRINT. UNLESS SPECIFIED DIMENSIONS IN mm [INCHES]		PART NO	
TOLERANCES ON: 2 PLC DEC ± - 3 PLC DEC ± - ANGLES ± -		AMP AMP Incorporated Harrisburg, PA 17105-3608	
MATERIAL -	DR 6-3-94 J. LIPPERT	NAME SOLDER JACK, 50Ω, SERIES BNC	
FINISH -	CHK 6-3-94 M. TOMCHAK	SIZE B	CAGE CODE 00779
	APPD 6-3-94 M. TOMCHAK	DRAWING NO 227715	
	APPD 6-3-94 J. LIPPERT	SCALE 4:1	SHEET 1 OF 1
	PRODUCT SPEC 108-12079		
	APPLICATION SPEC -		
	WEIGHT -		